

Erosion in a Bottle

DESCRIPTION:

Groups will build a model that demonstrates runoff and erosion, which can occur in both urban and agricultural settings.

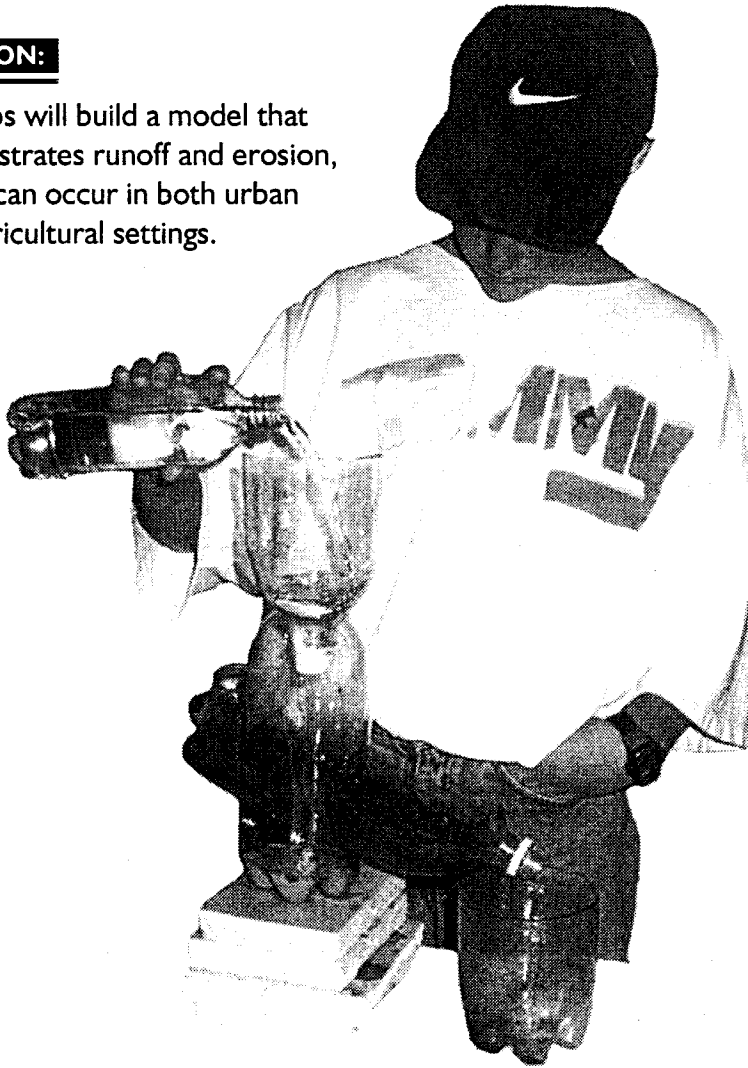

OBJECTIVES

By participating in this activity, your group will:

1. Understand what factors contribute to erosion and runoff in urban and agricultural settings.
2. Build a bottle runoff model.

3. Use the bottle runoff model to demonstrate runoff and erosion.

TIME

It will take approximately 30 minutes to build a bottle runoff model.

AGE

This is a good activity for 12 years and older. With guidance from adults, younger children can build a bottle runoff model.

COST

You will need to get two-liter soda bottles.

YOU WILL NEED:

To build one model:

- ◆ 4 two-liter plastic soda bottles
- ◆ One bottle cap
- ◆ A permanent marker
- ◆ Photocopies of tower hole pattern (back side of insert)
- ◆ Dark topsoil
- ◆ Sand
- ◆ Mulch or sod
- ◆ Water
- ◆ 2 two-cup measuring cups
- ◆ 2 containers such as glasses or small bowls
- ◆ Razor knife
- ◆ Scissors
- ◆ Push pin or ice pick/drill
- ◆ Powdered drink mix

BACKGROUND

Runoff and erosion are problems in both rural and urban areas.

Runoff is a term for the water that flows over the land and eventually reaches a water body. Runoff causes **erosion**, which is the wearing away of soil and rock by water or wind. Open fields, bare hillsides, and construction sites are prime candidates for erosion because the runoff water easily carries unprotected soil to surface water.

Soil and rocks that are washed into streams and rivers cause **sedimentation**. The buildup of sediment at the bottom of a stream or river creates a muddy bottom. This extra mud changes the living environment for many fish and wildlife, and can restrict water flow. Runoff nutrients, and toxics such as fertilizers and pesticides carried with the soil can cause rapid algae and weed growth that may harm fish and other aquatic organisms.

BUILDING A MODEL

Bottle 1: "The Support Tower"

1. Photocopy and cut out the tower pattern on the back page of the insert.
2. Cut the top off the bottle with a knife or scissors (see Diagram 1).
3. Choose a front and back on the tower and mark these locations with a marker or pen at the base of the bottle. You may want to use the side seams of the bottle as a guide for the front and back.

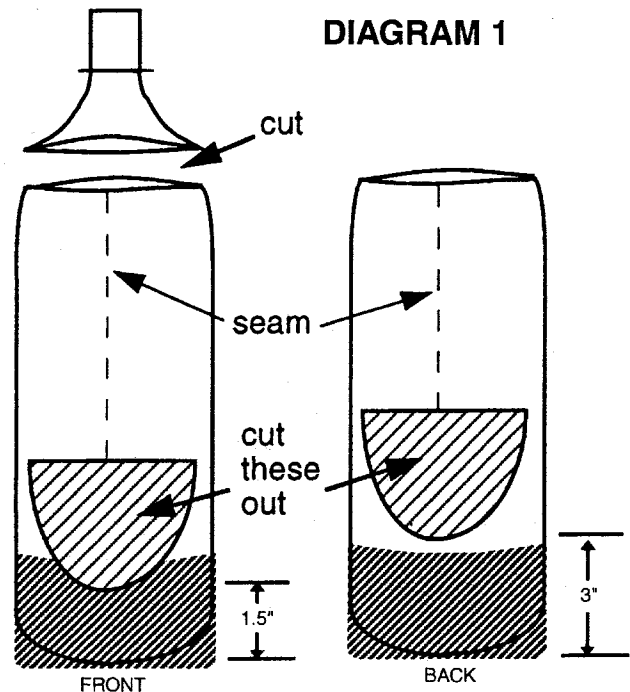

leave base on

4. Measure 1½ inches (4 cm) up from the "front" mark on the bottle. Make another mark.
5. Take the tower pattern and trace it on the front side of the bottle. The rounded edge or bottom of the pattern should be on the 1½-inch mark (see Diagram 1).
6. Turn the bottle around to the back mark.
7. Measure 3 inches (7.5 cm) up from the mark on the back of the bottle.
8. Using the tower pattern, trace it onto the back side of the bottle. The rounded edge of the pattern should be on the 3-inch mark (see Diagram 1).

9. Cut out both the front and back holes (recycle the plastic). Leave the base on the bottle for stability.

Bottles 2 & 3: "Soil Tray" (need at least two of these)

1. Use hot water to loosen the glue and remove the extra plastic base from the bottom of both bottles that will be used as soil trays (see Diagram 2).
2. Use a permanent marker to draw a line (baseline) around the base of the bottle about 2 inches from the bottom of the bottle.
3. Lay the bottle on its side.
4. Find the seams that run the length of the bottle. You can use these seams as a guide.

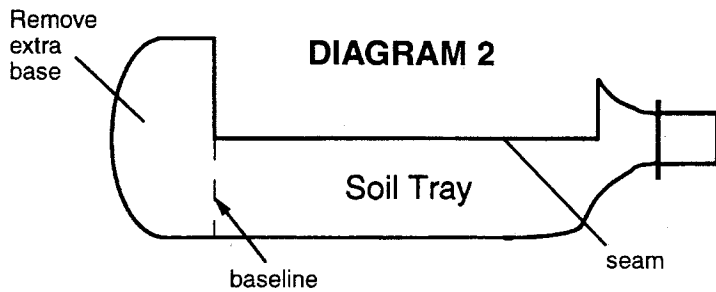

5. Use the marker to draw a line along each seam from the baseline to the neck of the bottle (see Diagram 2).
6. At the neck of the bottle, draw a line from one seam line to the other seam line.
7. Cut along lines and remove the side of the soil tray (recycle the plastic). The soil tray is ready to be filled with soil.
8. Repeat steps 1-7 for the second soil tray.

Filling the soil tray

1. With the bottle laying on its side, fill one bottle with about 1/2-inch of sand. This is the subsoil. Level the subsoil and gently press it down to make it firm.
2. Put 1/4 inch of moist topsoil over the sand. Remove or break up any soil clumps. The layers of soil should be easy to see through the side of the bottle (see Diagram 4).
3. The bare soil tray is done.
4. Repeat steps 1 and 2 for a second soil tray.

5. In the second soil tray, press mulch (grass clippings in the summer; finely shredded newspaper or wood chips in the winter) into the moist topsoil so most of the surface is covered. You may want to use a piece of sod instead of mulch.

Or, you can grow your own plants such as alfalfa sprouts or grass in the second soil tray. Growing plants will take some time.

6. Sprinkle about one half bottle cap full of powdered drink mix evenly over the surface of both trays. The mix represents some kind of fertilizer or pollution.

Bottle 4: "Rain Maker"

1. Cut the next bottle in half to form a funnel and a water container (see Diagram 3).
2. The funnel or top portion is the rain maker.
3. Poke holes in the bottle cap by using a push pin, ice pick or drill. Make nine holes. It's best to leave the rubber seal in the cap so water doesn't leak around the rim.

4. Screw the cap tightly on the rain maker and fill the rain maker about halfway with water to test whether all holes are free flowing. If the water is only dribbling out, enlarge the holes by wiggling the push pin back and forth a bit more.
5. The bottom half of the bottle can be used to hold the water added to the rain maker.

Putting the model together

1. Pour sand into the tower (Bottle 1) to make it stable.
2. Push the bare soil tray through the holes in the tower. The neck of the soil tray should be lower than the base of the soil tray (see Diagram 4, next page).

DIAGRAM 3

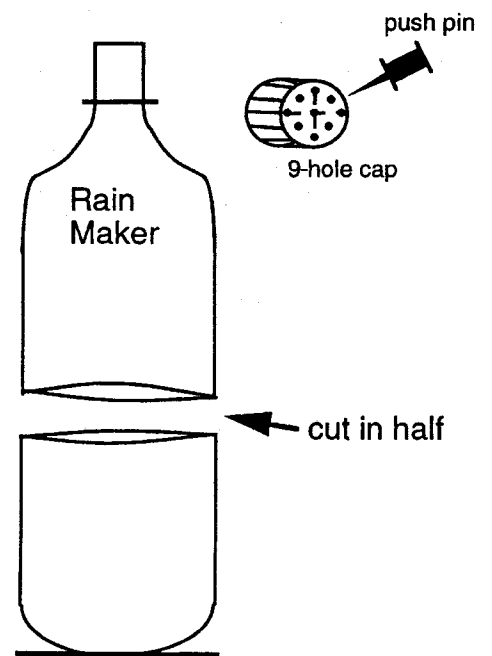
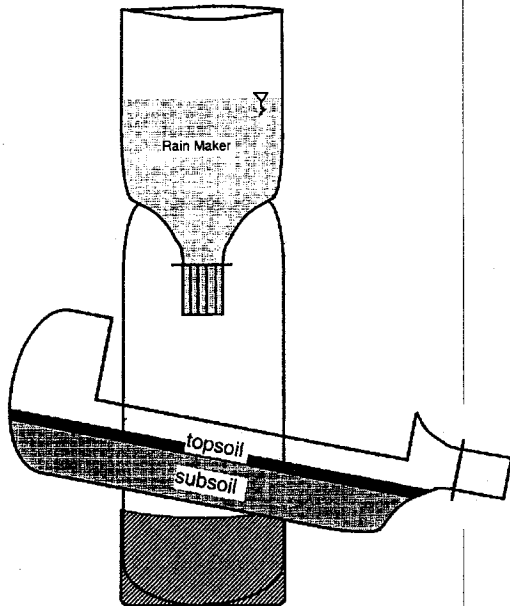

DIAGRAM 4



- Place the model on a block of wood or a platform so the mouth (bottle cap end) of the soil tray is high enough to place measuring cup beneath it.
- Insert the **empty** rain maker into the top of the tower.

Collecting runoff

- Use the two-cup measuring cup to collect runoff. It's important to use the same size collection container when comparing runoff between different demonstrations.

How to do the demonstration

- Pour water into two separate containers so both containers have two cups of water. This water will be added to the rain maker. Place the measuring cup below the soil tray to collect runoff (see Diagram 5).
- Dump the water from one container into the rain

maker.

- Observe the amount of drink mix and soil being "eroded" into the measuring cup.
- When all of the runoff water has flowed into the measuring cup, set it aside. You will need to use it to compare runoff with the next soil tray.
- Remove the first soil tray from the tower and replace it with the second soil tray (mulch tray).
- Repeat demonstration steps 2 through 4, but this time use the mulch tray and the second container of water.
- Compare the results.
 - Which measuring cup has

the most water? Colored water from drink mix?

- Was the mulch helpful in reducing the amount of runoff? Erosion?
- Was the topsoil washed away directly beneath the rain maker?

Look at the collection containers. Think of these containers as a stream or river. How would the "drink mix" affect water quality and aquatic life?

Produced for Water Action Volunteers, Spring, ©1999. Activity developed by: Kevin Fermanich, Mike Pelech, Scott Arnold, Rob Zemenchik and Peter Kling, with the Department of Soil Science at University of Wisconsin-Madison (608-262-2633).

The Water Action Volunteers (WAV) program is a cooperative effort between the University of Wisconsin-Extension and the Wisconsin Department of Natural Resources. For more information about the program, please contact the WAV Coordinator at 608-264-8948.

DIAGRAM 5

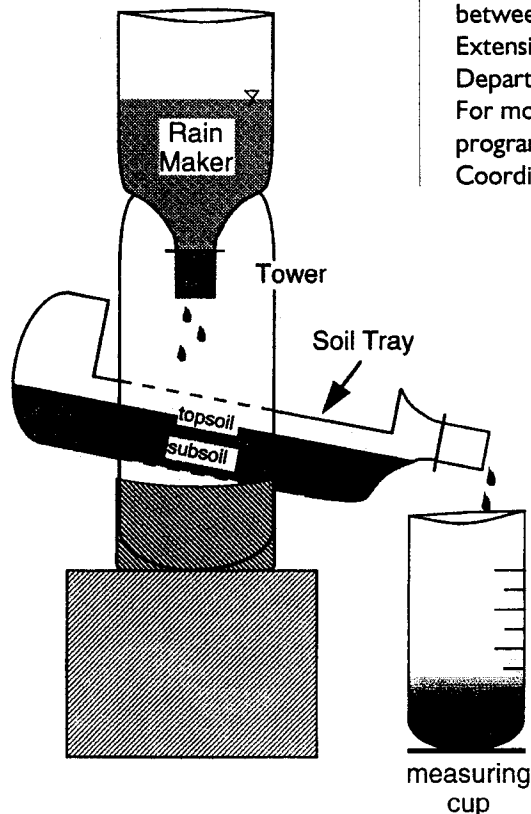

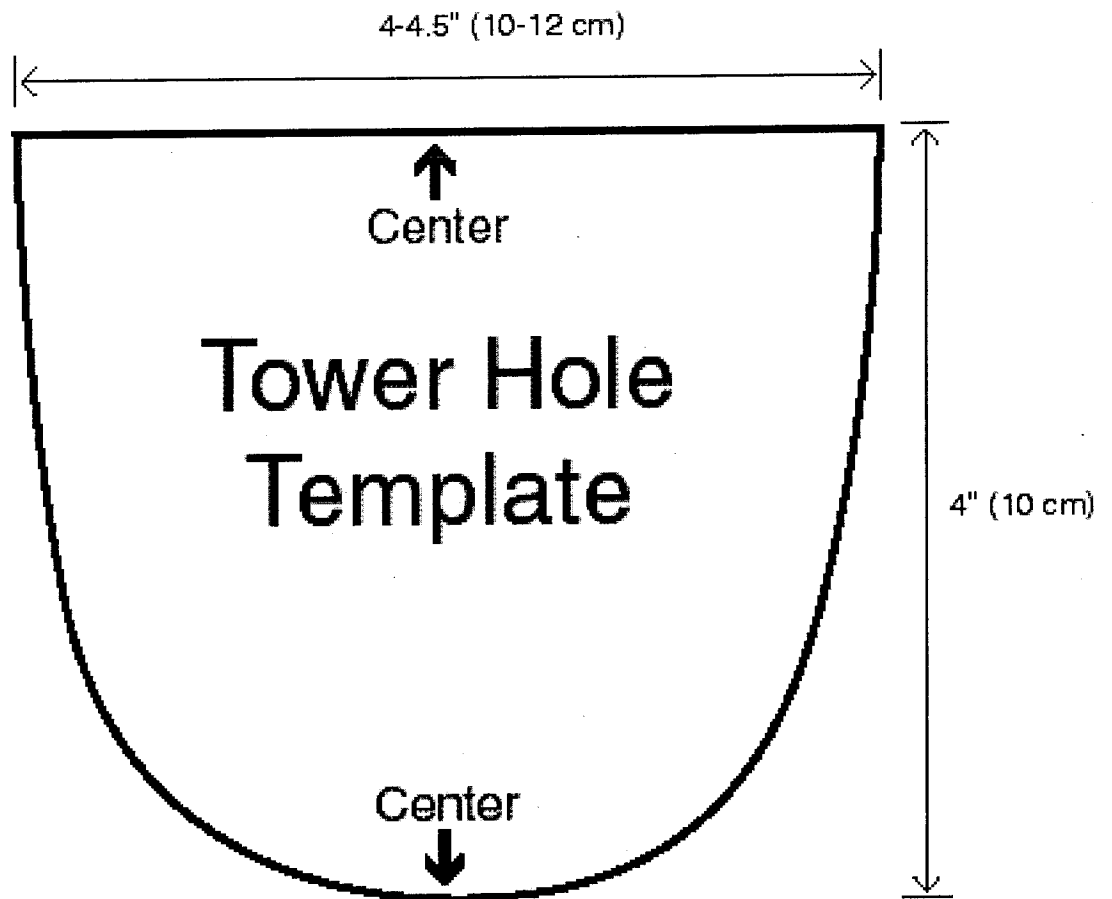

EXTRA IDEAS

Try these ideas to make your "Erosion in a Bottle" experiment even more interesting!

Create a filter strip.

A filter strip is an area of grass that slows runoff and captures soil and pollutants. To create an erosion model with a filter strip, make an extra soil tray with sod.

Then, let runoff from the bare soil tray pour onto the soil tray with sod and then into the measuring cup (see diagram below). This activity will demonstrate how filter strips help to prevent runoff pollution.

Different amounts of rainfall.

Experiment with the amount of "rainfall" and how this affects the amount of erosion.

Produced for Water Action Volunteers, Winter, ©1998. Activity developed by: Kevin Fermanich, Mike Pelech, Scott Arnold, Rob Zemenchik and Peter Kling, Department of Soil Science at University of Wisconsin-Madison (608-262-2633).

